



ODO RTU™ User Manual

OPTICAL DISSOLVED OXYGEN & TEMPERATURE SENSOR



a xylem brand

ODOTM RTU

The information contained in this manual is subject to change without notice.

Effort has been made to make the information in this manual complete, accurate, and current.

The manufacturer shall not be held responsible for errors or omissions in this manual.

Consult YSI.com for the most up-to-date version of this manual.

Thank you for purchasing a YSI ODO RTU dissolved oxygen probe. This manual covers setup, operation, and functionality.

Safety Information

Please read this entire manual before unpacking, setting up or operating this equipment. Pay attention to all precautionary statements. Failure to do so could result in serious injury to the operator or damage to the equipment. Do not use or install this equipment in any manner other than that specified in this manual.

The manufacturer is not responsible for any damages due to misapplication or misuse of this product including, without limitation, direct, incidental and consequential damages, and disclaims such damages to the full extent permitted under applicable law. The user is solely responsible to identify critical application risks and install appropriate mechanisms to protect processes during a possible equipment malfunction.

Precautionary Symbols

NOTE: *Information that requires special emphasis*

NOTICE: Indicates a situation which, if not avoided, may cause damage to the instrument

 **CAUTION:** Indicates a potentially hazardous situation that may result in minor or moderate injury

 **WARNING:** Indicates a potentially or imminently hazardous situation which, if not avoided, could result in death or serious injury

Product Components

Carefully unpack the instrument and accessories and inspect for damage. If any parts or materials are damaged, contact YSI Customer Service at 800-897-4151 (+1 937 767-7241) or the authorized YSI distributor from whom the instrument was purchased.

TABLE OF CONTENTS

1. Introduction

- 1.1 Probe Assembly
- 1.2 Preparing the Probe and Sensor

2. Setup

- 2.1 Wiring
- 2.2 Power

3. Calibration

- 3.1 Calibration Setup
- 3.2 Conductivity
- 3.3 Dissolved Oxygen

4. Maintenance and Storage

- 4.1 Conductivity Sensor
- 4.2 Optical Dissolved Oxygen Sensor

5. Modbus Configuration & Commands

- 5.1 Modbus Serial Configuration
- 5.2 Device Information
- 5.3 Data
- 5.4 Calibration
- 5.5 User Values for Derived Parameters
- 5.6 Conductivity Settings
- 5.7 Appendix A: Register Mapping Tables

6. Accessories

- 6.1 Ordering

7. Safety and Support

- 7.1 Service Information
- 7.2 Technical Support
- 7.3 Declaration of Conformity
- 7.4 Warranty

8. Appendices

- 8.1 Appendix B - DO% Calibration Values
- 8.2 Appendix C - Oxygen Solubility Table



THIS IS AN
INTERACTIVE DOCUMENT

When viewing this document as an Adobe™ PDF, hovering your cursor over certain phrases will bring up the finger-point icon. Clicking elements of the Table of Contents, website URLs, or references to certain sections will take you automatically to those locations.

1. Introduction

1.1 Probe Assembly

ODO RTU assemblies feature integral sensors – this means that these sensors cannot be removed from the probe and cable. Sensor caps are user-replaceable and need to be changed out about once per year.

NOTE: Each ODO cable assembly and sensor cap includes an instruction sheet with important information unique and specific to each individual sensing cap. These are important because they include calibration coefficients needed for proper setup.

NOTE: A new cable/probe assembly already has a sensor cap installed and the sensor cap coefficients are preloaded into the probe at the factory.

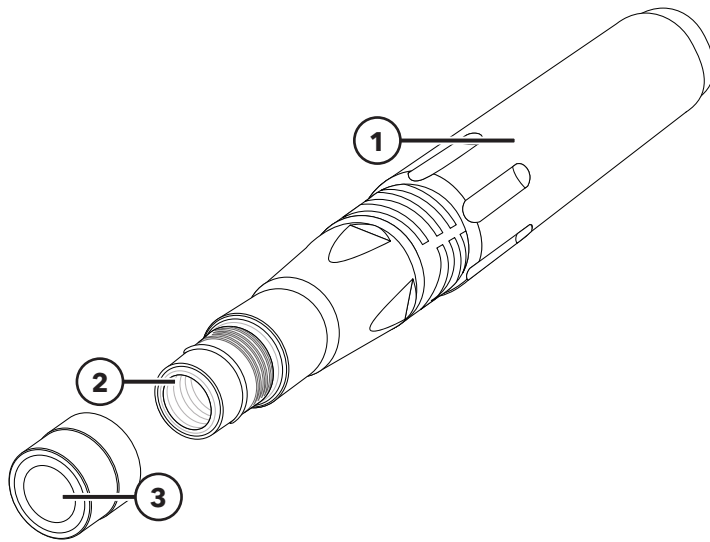

1 Probe
2 Sensor
3 Sensor Cap

Figure 1 ODO probe and cable assembly

1.2 Preparing the Probe and Sensor

1. Remove the metal probe guard from the probe by turning it counterclockwise.
2. Remove the red storage cap which, contains a moist sponge, from the end of the probe by pulling it straight off the sensor. Save this to use later for long-term storage.
3. Reinstall the probe guard by sliding it carefully over the sensor and then threading it onto the cable assembly with a clockwise rotation.

CAUTION: It is important to always store your sensor in a moist environment so the sensor cap does not dry out. A gray calibration/storage sleeve is shipped with your cable assembly for an easy storage option. Simply moisten the sponge with a small amount of clean water and slide the sleeve over the probe guard to create a moist atmosphere for the sensor.

2. Setup

2.1 Wiring

ODO RTU is configured with native Modbus output built around the RS485 standard physical layer. The flying lead cable is terminated with its ends trimmed and tinned for easy wiring. These ends can be connected to a third party Modbus capable PLC or data logger.

ODO/T and ODO/CT RTU probe and cable assemblies with hardware prior to version 1.0 are internally terminated. In this case, only **one** probe and cable assembly can be connected in a network.

ODO/T and ODO/CT RTU probe and cable assemblies with hardware 1.0 or greater are not internally terminated and **support multi-drop network configurations**. These units require a 120 Ohm termination resistor between Modbus A and B wires on the last probe/cable assembly in the daisy chain network. Single sensor networks with hardware version 1.0 or greater will also require the termination resistor.

The hardware version can be queried via Modbus. Additionally, any probe and cable assembly with a serial number of 22H or greater will have hardware version 1.0 or greater.

Wire Color	Purpose
Red	Power
Green	Ground
White	Modbus A
Black	Modbus B

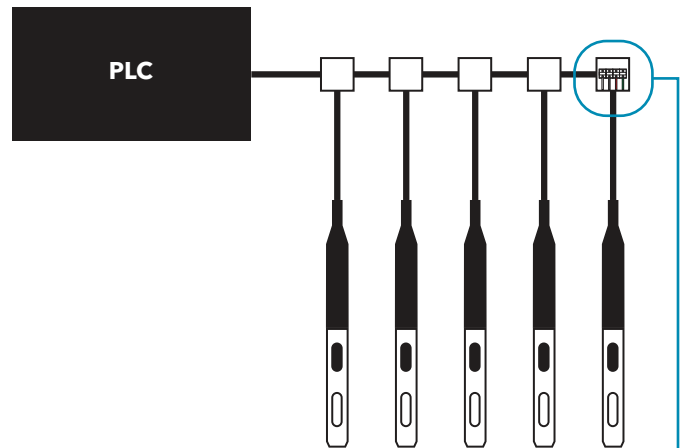

Figure 2 ODO multi-drop network configuration

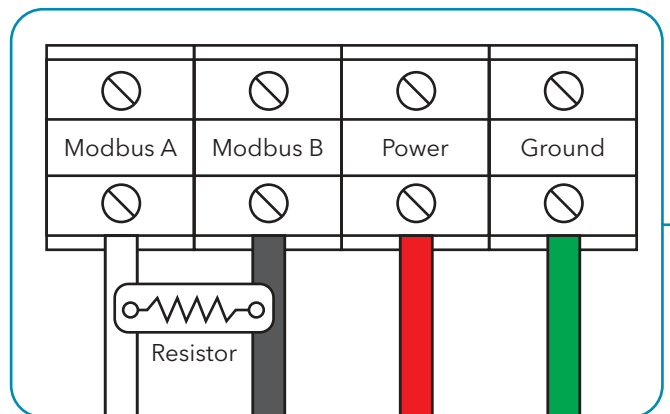

Figure 3 Wiring terminal close-up

2.2

Power

ODO RTU requires 10-16 VDC with a maximum current of 15 mA. The sensor will pull 0.12 W while powered. Once power is supplied to the sensor, the probe will complete a 1-2 second power up sequence before it can be queried for a value.

3. Calibration

ODO RTU requires periodic calibration. Calibration procedures follow the same basic steps with variations for the specific parameter. The specific Modbus commands that accompany the calibration can be found in the [Modbus Configuration and Commands](#) section of this document

3.1

Calibration Setup

Make sure the calibration cup, sensor guard, and all sensors are clean. YSI strongly recommends installing the sensor guard before placing the sensors into the calibration cup.

For highest data accuracy, thoroughly rinse the calibration cup and sensors with a small amount of the calibration standard for the sensor to be calibrated. Discard the rinse standard, and proceed with a fresh standard.

Be careful to avoid cross-contamination with other standards between calibrations by thoroughly rinsing with DI water and drying the calibration cup and sensors.

3.2 Conductivity

If installed, the conductivity/temperature sensor can measure and calculate conductivity, specific conductance (temperature compensated conductivity), salinity, non-linear function (nLF) conductivity, TDS, resistivity, and density. Calibration is only available for specific conductance, conductivity, and salinity. Calibrating one of these options automatically calibrates the other conductivity/temperature parameters listed above. For both ease of use and accuracy, YSI recommends calibrating specific conductance.

Select the appropriate calibration standard for the conductivity of the sampling environment. Standards at least 1 mS/cm (1000 $\mu\text{S}/\text{cm}$) are recommended for the greatest stability. For fresh water applications, calibrate to 1,000. For salt water applications, calibrate to 50,000 μS .

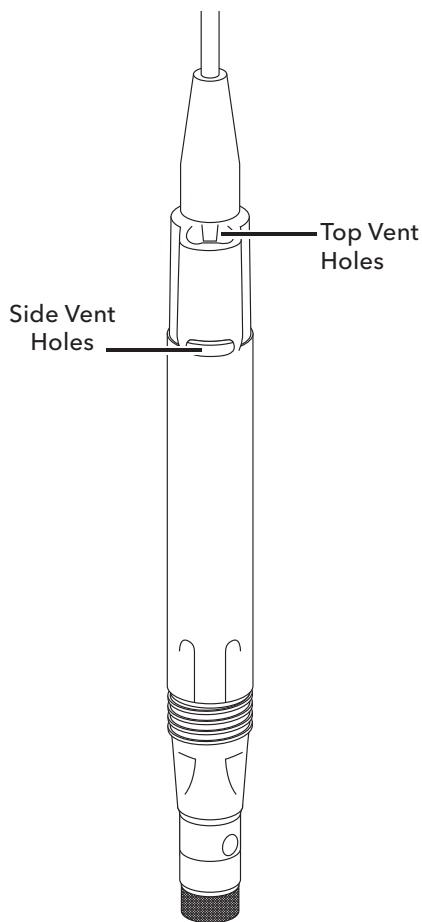

Figure 4 ODO/CT Cable Assembly

Conductivity Calibration

1. Make sure the conductivity sensor is clean prior to calibration. If necessary, clean the conductivity cell with the supplied soft brush.
2. Place the correct amount of conductivity standard into a clean and dry or pre-rinsed calibration cup.
3. Carefully immerse the sensors into the solution. Make sure the solution is above the vent holes on the side of the conductivity sensor.

If using the ODO/CT assembly, ensure the vent holes at the top of the sensor are completely immersed and the solution level is at least 1 cm higher than the top vent holes (Figure 4). A graduated cylinder is included with ODO/CT cable assemblies for the purpose of calibrating conductivity.

4. Gently rotate and/or move the sensor up and down to remove any bubbles from the conductivity cell. Allow at least 40 seconds for temperature equilibration before writing the value with the appropriate Modbus command (see [Modbus Configuration and Commands](#) for more details).
5. Rinse the sensor in clean water then dry.

NOTE: If the data is not stabilized after 40 seconds, gently rotate the sensor or remove/reinstall the calibration cup to make sure that no air bubbles are in the conductivity cell.

If you get calibration error messages, check for proper sensor immersion, verify the calibration solutions is fresh, the correct value has been entered into the handheld, and/or try cleaning the sensor.

3.3 Dissolved Oxygen

ODO calibration requires the current “true” barometric pressure. Make sure that the barometric pressure has been input properly and accurately prior to ODO calibration. See Modbus Configuration and Commands for more details.



Figure 5 ODO Cable Assembly in calibration sleeve

ODO% - Water Saturated Air Calibration

1. Place a small amount of clean water (5 mL) in the calibration cup or a wet sponge into the calibration sleeve (Figure 5).
2. Make sure there are no water droplets on the ODO sensor cap or temperature sensor.
3. Attach the probe guard and carefully slide into the calibration cup. Make sure a seal is not created around the probe. Atmospheric venting is required for accurate calibration.
4. Turn the instrument on and wait approximately 5 to 15 minutes for the air in the storage container to be completely saturated with water.
5. Allow at least 40 seconds for equilibration before writing the value with the appropriate Modbus command (see [Modbus Configuration and Commands](#) for more details).

ODO mg/L Calibration

1. Place the ODO and conductivity/temperature sensor into a water sample that has been titrated by the Winkler method to determine the dissolved oxygen concentration in mg/L.
2. Enter the dissolved oxygen concentration of the sample in mg/L.
3. Allow at least 40 seconds for equilibration before writing the value with the appropriate Modbus command (see [Modbus Configuration and Commands](#) for more details).
4. Rinse the bulkhead and sensors in clean water then dry.

ODO Zero Point Calibration

1. Place the sensor in a solution of zero DO.
NOTE: A zero DO solution can be made by dissolving approximately 8-10 grams of sodium sulfite into 500 mL of tap water. Mix the solution thoroughly. It may take the solution 60 minutes to be oxygen-free.
2. Allow at least 40 seconds for equilibration before writing the value with the appropriate Modbus command (see [Modbus Configuration and Commands](#) for more details).
3. Thoroughly rinse the bulkhead and sensors in clean water then dry.
4. Perform a ODO % water-saturated air calibration after performing a zero point calibration.

4. Maintenance and Storage

Follow all maintenance and storage procedures in this section. Incorrect or unapproved maintenance and/or storage can cause sensor or cable damage not covered by the warranty.

Storage terms are defined as follows:

Short-term Storage = Less than 4 weeks

Short-term storage is appropriate when the cables, and sensors will be used at regular intervals (daily, weekly, etc.).

Long-term Storage = More than 4 weeks

During long periods of inactivity, such as the "off-season" for environmental monitoring, the instrument, sensors, and cables should be placed in long-term storage.

YSI recommends cleaning and maintenance before long-term storage.

4.1 Conductivity Sensor

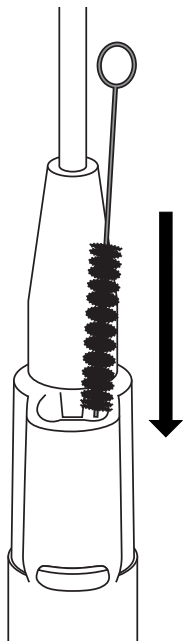

Figure 6 Channel brush

The conductivity channels should be cleaned after each use. Dip the sensor's cleaning brush (included with the maintenance kit) in clean water, insert the brush at the top of the channels, and sweep the channels 15 to 20 times (Figure 6).

If deposits have formed on the electrodes, use a mild solution of dish soap and water to brush the channels. For heavy deposits, soak the sensor in white vinegar, then scrub with the cleaning brush. Rinse the channels with clean water following the sweepings or soak.

The ODO/CT probe must be stored in a moist environment.

4.2

Optical Dissolved Oxygen Sensor

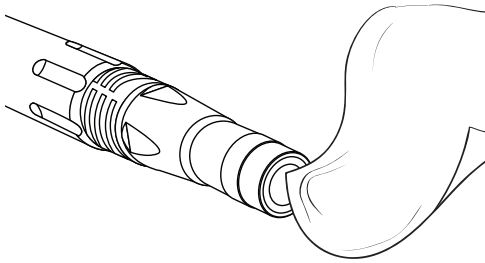

Figure 7 Wiping the ODO sensor window



Figure 8 ODO short-term storage

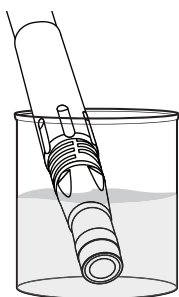

Figure 9 ODO rehydration

The ODO sensor should be kept clean since some types of fouling may consume oxygen which could affect the dissolved oxygen measurements.

To clean the sensor cap, gently wipe away any fouling with a lens cleaning tissue that has been moistened with water to prevent scratches (Figure 7). Do not clean the ODO sensor with organic solvents as they may damage the cap.

To minimize sensor drift, always store the ODO sensor in a wet or water-saturated air environment.

Short-term Storage:

Store the ODO sensor in a moist air environment. A storage sleeve with a wet sponge or the calibration cup with a small amount of water is recommended.

Long-term Storage:

- **Method 1:** Submerge the sensing end of the sensor in a container of distilled or deionized water. Periodically check the level of the water to make sure that it does not evaporate.
- **Method 2:** Wet the sponge located in the cap originally included with the ODO sensor, then install on sensing end of the ODO sensor. Replace the sponge if it becomes dirty.

A gray storage sleeve is shipped with the cable for an easy storage option. Simply moisten the sponge with a small amount of clean water and slide the sleeve over the probe guard to create a moist atmosphere for the sensor.

ODO Sensor Rehydration

If the ODO sensor has accidentally been left dry for longer than 8 hours, it must be rehydrated. To rehydrate, soak the ODO sensor in room temperature tap water for approximately 24 hours. After the soak, calibrate the sensor.

ODO Sensor Cap

Optical DO Extended Warranty Sensor Caps [SKU: 627180] are warrantied for 24 months. Depending on usage and storage practices, the cap may last longer than its warranty period.

As the ODO sensor caps ages, deterioration of the dye layer can reduce measurement stability and response time. Periodically inspect the sensor cap for damage and large scratches in the dye layer. Replace the cap when readings become unstable and cleaning the cap and DO recalibration do not remedy the symptoms.

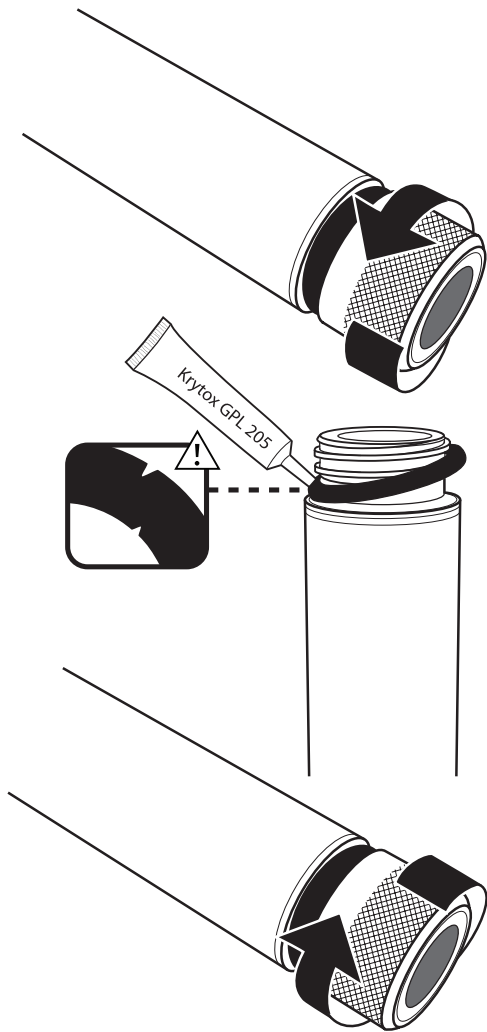

Figure 10 ODO cap replacement

ODO Sensor Cap Replacement

The instruction sheet shipped with the replacement ODO sensor cap includes the calibration coefficients specific to that sensor cap. Make sure to save the ODO sensor cap instruction sheet in case you need to reload the calibration coefficients.

1. Remove the old sensor cap assembly from the probe by grasping the probe body with one hand and rotating the sensor cap counterclockwise until it is completely free. Do not use any tools for this procedure.
2. Carefully remove the o-ring by pinching it with your fingers and rolling it up. Do not use any tools to remove the o-ring. Clean the area of any debris with a lens cleaning tissue.
3. Install the new o-ring that is included with the replacement sensor cap.
4. Apply a thin coat of o-ring lubricant (included with the new cap) to the installed o-ring. Remove any excess o-ring lubricant with a lens cleaning tissue. Be careful to avoid contact with the sensor lens.
5. Inspect the sensor lens for any moisture or debris. If necessary, wipe the lens carefully with a non-abrasive, lint-free cloth to prevent scratches. Do not use organic solvents to clean the ODO sensor lens.
6. Remove the new sensor cap from its hydrated container and dry the inside cavity of the sensor cap with lens cleaning tissue. Make sure the cavity is completely dry before proceeding with the installation.
7. Using clockwise motion, thread the new sensor cap onto the probe assembly until it is finger-tight. The o-ring should be compressed between the sensor cap and probe. Do not over-tighten the sensor cap and do not use any tools for the installation process.
8. After installing the new sensor cap, store the sensor in either water or in the water-saturated air storage chamber.

NOTE: Be sure to update the ODO Sensor Cap Coefficients after replacement.

Updating the ODO Sensor Cap Coefficients

After installing a new sensor cap, locate the Calibration Code Label on the ODO Sensor Cap Instruction Sheet. This contains the calibration codes for this particular sensor cap. The value of each cap coefficient (K1 through KC) can be written with the appropriate Modbus command (see [Modbus Configuration and Commands](#) for more details).

If errors are made in entering the Sensor Cap Coefficients, the instrument will block the update and an error message will appear on the display. If you see this error message, re-enter the coefficients and check them carefully.

NOTE: After entering the sensor cap coefficients, the ODO sensor must be calibrated.

5. Modbus Configuration & Commands

5.1 Modbus Serial Configuration

ODO RTU operates over RS485. The serial configuration can be modified, including the baud rate, parity, and Modbus slave address. By default, the baud rate is 9600, slave address is 0x01, and parity is even. As per the Modbus serial specification, there is one stop bit when parity is set, and two stop bits when there is no parity. All values are big-endian byte ordered.

To network multiple ODO RTU probes on the same network, **each probe needs a unique Modbus address**. The factory-default Modbus address for all ODO RTUs is: 0x01.

To change the Modbus address, connect the probe to a Modbus master device and change the address. After changing to a unique address, that probe assembly can be connected to an existing network.

Or, alternatively, you can connect each probe to the Modbus network and assign the addresses in the network. This is only an option as long as there is not a device already on the network with an address of 0x01. This would have to be done one at a time, i.e. connect one probe, assign the address and then connect the next probe.

Slave Addresses

The slave address is set using a single register write command (function code 0x06) of address 0x0000. Addresses in range of 0x01 to 0xF7 are supported. Devices will allow broadcast write access using address 0x00. The default address is 0x01.

Request		
Function Code	1 byte	0x06
Register Address	2 bytes	0x0000
Register Value	2 bytes	0x0001

Response		
Function Code	1 byte	0x06
Register Address	2 bytes	0x0000
Register Value	2 bytes	0x0001

Error		
Error Code	1 byte	0x86
Exception Code	1 bytes	0x03 (Illegal Data Value)

The slave address can also be read using a read holding registers command (function code 0x03) of address 0x0000

Request		
Function Code	1 byte	0x03
Register Address	2 bytes	0x0000
Number Registers	2 bytes	0x0001

Response		
Function Code	1 byte	0x03
Byte Count	1 byte	0x02
Register Value	2 bytes	0x0001

Baud Rate and Parity

The baud rate and parity is set simultaneously using a single register write command (function code 0x06) of address 0x0001. The upper byte defines the parity, and the lower byte defines the baud rate from a list of standards.

Parity	
None	0x00
Odd	0x01
Even	0x02

Baud Rate	
9600	0x00
19200	0x01
38400	0x02
57600	0x03
115200	0x04

Request		
Function Code	1 byte	0x06
Register Address	2 bytes	0x0001
Register Value	2 bytes	0x0200

Response		
Function Code	1 byte	0x06
Register Address	2 bytes	0x0001
Register Value	2 bytes	0x0200

Error		
Error Code	1 byte	0x86
Exception Code	1 bytes	0x03 (Illegal Data Value)

The serial configuration can also be read using a read holding registers command (function code 0x03) of address 0x0000.

Request		
Function Code	1 byte	0x03
Register Address	2 bytes	0x0001
Register Value	2 bytes	0x0001

Response		
Function Code	1 byte	0x03
Register Address	2 bytes	0x0002
Register Value	2 bytes	0x0200

5.2

Device Information

Device information is available as read-only using a read holding registers command (function code 0x03) starting at address 0x1000. It will identify the product, firmware, and hardware versions. Values can be read as a subset or in a complete block. The submodel is especially useful, as it indicates whether or not conductivity values are available. The manufacturing serial number is 9 characters long, with the last byte padded by a NULL character.

Address	Description	R/W	Type	Default
0x1000	Product [1:0]	R	U16	0x0003
0x1001	Model [1:0]	R	U16	0x0001
0x1002	Submodel [1:0]	R	U16	0x0001 (CT) 0x0002 (T)
0x1003	Firmware Major Revision [1:0]	R	U16	N/A
0x1004	Firmware Minor Revision [1:0]	R	U16	N/A
0x1005	Firmware Subminor Revision [1:0]	R	U16	N/A
0x1006	Hardware Major Revision [1:0]	R	U16	N/A
0x1007	Hardware Minor Revision [1:0]	R	U16	N/A
0x1008	Manufacturing Serial Number [0:8] + pad	R	ASCII	N/A
0x1009				
0x100A				
0x100B				
0x100C				
0x100D	Printed Circuit Board Serial Number [0:7]	R	ASCII	N/A
0x100E				
0x100F				
0x1010				

Request		
Function Code	1 byte	0x03
Register Address	2 bytes	0x1000
Number Registers	2 bytes	0x0008

Response		
Function Code	1 byte	0x03
Byte Count	1 byte	0x10
Register Values	16 bytes	Product Model Submodel Firmware Major Revision Firmware Minor Revision Firmware Subminor Revision Hardware Major Revision Hardware Minor Revision

5.3

Data

Values for available parameters are available by via a read input registers command (function code 0x04). Most of these values are 32-bit IEEE-754 floating point numbers in big endian format. Each value is a combination of two registers. The read must read an entire value, so the read must start at an even (or zero) register address, and read an even number of registers. Any values that are not available, such as conductivity measurements in an ODO/T device or reserved space will return a NaN (0xFFFFFFFF)..

Address	Description	R/W	Type
0x0000	ODO Saturation (%) [3:0]	R	Float
0x0001			
0x0002	ODO (mg/L) [3:0]	R	Float
0x0003			
0x0004	ODO Local Barometer Compensated (%) [3:0]	R	Float
0x0005			
0x0006	Temperature (C) [3:0]	R	Float
0x0007			
0x0008	Reference Temperature (C) [3:0]	R	Float
0x0009			
0x000A	Time Since Boot (ms) [3:0]	R	U32
0x000B			
0x000C	*Conductivity (us/cm) [3:0]	R	Float
0x000D			
0x000E	*Specific Conductivity (us/cm) [3:0]	R	Float
0x000F			
0x0010	*Salinity (ppt) [3:0]	R	Float
0x0011			
0x0012	*Conductivity nLF (us/cm) [3:0]	R	Float
0x0013			
0x0014	*Total Dissolved Solids (mg/L) [3:0]	R	Float
0x0015			
0x0016	Reserved [3:0]	R	Float
0x0017			
0x0018	Reserved [3:0]	R	Float
0x0019			
0x001A	Reserved [3:0]	R	Float
0x001B			
0x001C	Reserved [3:0]	R	Float
0x001D			
0x001E	Reserved [3:0]	R	Float
0x001F			

*Only available in ODO/CT devices

Request		
Function Code	1 byte	0x04
Register Address	2 bytes	0x0000
Number Registers	2 bytes	0x0020

Response		
Function Code	1 byte	0x04
Byte Count	1 byte	0x40
Register Values	64 bytes	ODO Saturation (%) [3:0] ODO (mg/L) [3:0] ODO Local Barometer Compensated (%) [3:0] Temperature (C) [3:0] Ref Temperature (C) [3:0] Time Since Boot (ms) [3:0] Conductivity (us/cm) [3:0] Specific Conductivity (us/cm) [3:0] Salinity (ppt) [3:0] Conductivity nLF (us/cm) [3:0] Total Dissolved Solids (mg/L) [3:0] Reserved [3:0] Reserved [3:0] Reserved [3:0] Reserved [3:0] Reserved [3:0] Reserved [3:0]

Error		
Error Code	1 byte	0x84
Exception Code	1 bytes	0x02 (Illegal Address)

5.4

Calibration

Assuming the same standard, calibration commands may be sent as a broadcast message to calibrate every sensor on the network.

ODO

It is imperative to keep the ODO user calibration up to date as well as entering new coefficients when the cap is replaced. These values are supplied with replacement caps.

Factory Reset

ODO values can be reset to the factory calibration by issuing a write single register command (function code 0x06) at address 0x0200 with a value of 0x0001.

Request		
Function Code	1 byte	0x06
Register Address	2 bytes	0x0200
Register Value	2 bytes	0x0001

Last Calibration Time and QC Score

The time of the last ODO calibration and QC score can be queried to help track internal processes for keeping the devices properly calibrated. The last time must be maintained during calibrations by the user. These registers do not support writes, as the time is written in each calibration command. This is only intended to be read. Last calibration time is a 32-bit (two register) value, and is recommended to be set as epoch time. The last calibration time and QC score are available as read-only using a read holding registers command (function code 0x03) starting at address 0x0210.

QC Score	
Best	0x00
OK	0x01
Bad	0x02

Address	Description	R/W	Type	Default
0x0210	ODO Last Calibration Time (s) [3:0]	R	U32	N/A
0x0211				
0x0212	ODO QC Score	R	U16	N/A

Request		
Function Code	1 byte	0x03
Register Address	2 bytes	0x0210
Number Registers	2 bytes	0x0003

Response		
Function Code	1 byte	0x03
Byte Count	1 byte	0x06
Register Values	6 bytes	ODO Last Calibration Time (s) [3:0] ODO QC Score

Zero Calibration

ODO zero point calibration is accomplished by writing an entire block of values (non-divisible) using a write multiple registers command (function code 0x10). Last calibration time can subsequently be read to verify.

Address	Description	R/W	Type	Default
0x0220	ODO Zero Calibration Time (s) [3:0]	W	U32	N/A
0x0221				

Request		
Function Code	1 byte	0x10
Register Address	2 bytes	0x0220
Number Registers	2 bytes	0x0002
Byte Count	1 byte	0x04
Register Values	4 bytes	ODO Zero Calibration Time (s) [3:0]

Percent Saturation Calibration

ODO percent saturation calibration is accomplished by writing an entire block of values (non-divisible) using a write multiple registers command (function code 0x10). Last calibration time can subsequently be read to verify. This calibration is done in 100% saturated water. Barometric pressure is required to perform the calibration.

Address	Description	R/W	Type	Default
0x0230	ODO % Calibration Time (s) [3:0]	W	U32	N/A
0x0231				
0x0232	ODO % Calibration Barometer (mmHg) [3:0]	W	Float	N/A
0x0233				

Request		
Function Code	1 byte	0x10
Register Address	2 bytes	0x0230
Number Registers	2 bytes	0x0004
Byte Count	1 byte	0x08
Register Values	8 bytes	ODO % Calibration Time (s) [3:0] ODO % Calibration Barometer (mmHg) [3:0]

mg/L Calibration

ODO mg/L calibration is accomplished by writing an entire block of values (non-divisible) using a write multiple registers command (function code 0x10). Last calibration time can subsequently be read to verify. Salinity values are required for ODO mg/L calibration. If conductivity values are available (ODO/CT), the user-provided salinity value will be overridden with the internal salinity calculation. The user may just set this value to zero.

Address	Description	R/W	Type	Default
0x0240	ODO mg/L Calibration Time (s) [3:0]	W	U32	N/A
0x0241				
0x0242	ODO mg/L Calibration Value (mg/L) [3:0]	W	Float	N/A
0x0243				
0x0244	ODO mg/L Calibration Salinity (ppt) [3:0]	W	Float	N/A
0x0245				

Request		
Function Code	1 byte	0x10
Register Address	2 bytes	0x0240
Number Registers	2 bytes	0x0006
Byte Count	1 byte	0x0C
Register Values	12 bytes	ODO mg/L Calibration Time (s) [3:0] ODO mg/L Calibration Value [3:0] ODO mg/L Calibration Salinity (ppt) [3:0]

ODO Cap Replacement

When replacing an ODO cap, new coefficients are required. These values will be included with the cap replacement. The coefficients are written in an entire block of values (non-divisible) using a write multiple registers command (function code 0x10). ODO Cap Replacement Time (s) is tracked by the user, and is suggested to hold an epoch timestamp for the operation.

Address	Description	R/W	Type	Default
0x0100	ODO Cap Coefficient K1 [3:0]	RW	U32	N/A
0x0101				
0x0102	ODO Cap Coefficient K2 [3:0]	RW	U32	N/A
0x0103				
0x0104	ODO Cap Coefficient K3 [3:0]	RW	U32	N/A
0x0105				
0x0106	ODO Cap Coefficient K4 [3:0]	RW	U32	N/A
0x0107				
0x0108	ODO Cap Coefficient K5 [3:0]	RW	U32	N/A
0x0109				
0x010A	ODO Cap Coefficient K6 [3:0]	RW	U32	N/A
0x010B				
0x010C	ODO Cap Coefficient K7 [3:0]	RW	U32	N/A
0x010D				
0x010E	ODO Cap Coefficient KC [3:0]	RW	U16	N/A
0x010F	ODO Cap Replacement Time (s) [3:0]	RW	U32	N/A
0x0110				

Request		
Function Code	1 byte	0x10
Register Address	2 bytes	0x0100
Number Registers	2 bytes	0x0011
Byte Count	1 byte	0x22
Register Values	34 bytes	ODO Cap Coefficient K1 [3:0] ODO Cap Coefficient K2 [3:0] ODO Cap Coefficient K3 [3:0] ODO Cap Coefficient K4 [3:0] ODO Cap Coefficient K5 [3:0] ODO Cap Coefficient K6 [3:0] ODO Cap Coefficient K7 [3:0] ODO Cap Coefficient KC ODO Cap Replacement Time (s) [3:0]

ODO Cap Serial Number

The serial number of the ODO cap is available for lot tracking purposes and is available as read-only using a read holding registers command (function code 0x03) starting at address 0x0120. The value is a nine character ASCII string with a NULL character padding as the unused last byte returned.

Address	Description	R/W	Type	Default
0x0120	ODO Cap Serial Number [0:8] + pad	R	ASCII	N/A
0x0121				
0x0122				
0x0123				
0x0124				

Request

Function Code	1 byte	0x03
Register Address	2 bytes	0x0120
Number Registers	2 bytes	0x0005

Response

Function Code	1 byte	0x03
Byte Count	1 byte	0x0A
Register Values	10 bytes	ODO Cap Serial Number [0:8] + pad

Conductivity

Factory Reset

ODO values can be reset to the factory calibration by issuing a write single register command (function code 0x06) at address 0x0200 with a value of 0x0001.

Request		
Function Code	1 byte	0x06
Register Address	2 bytes	0x0300
Register Value	2 bytes	0x0001

Last Calibration Time and QC Score

The time of the last conductivity calibration and QC score can be queried to help track internal processes for keeping the devices properly calibrated. The last time must be maintained during calibrations by the user. These registers do not support writes, as time is written in each calibration command. This is only intended to be read. Last calibration time is a 32-bit (two register) value, and is recommended to be set as epoch time. The last calibration time and QC score are available as read-only using a read holding registers command (function code 0x03) starting at address 0x0310.

QC Score	
Best	0x00
OK	0x01
Bad	0x02

Address	Description	R/W	Type	Default
0x0310	Conductivity Last Calibration Time (s) [3:0]	R	U32	N/A
0x0311				
0x0312	Conductivity QC Score	R	U16	N/A

Request		
Function Code	1 byte	0x03
Register Address	2 bytes	0x0310
Number Registers	2 bytes	0x0003

Response		
Function Code	1 byte	0x03
Byte Count	1 byte	0x06
Register Values	6 bytes	Conductivity Last Calibration Time (s) [3:0] Conductivity QC Score

µs/cm Calibration

Conductivity µs/cm calibration is accomplished by writing an entire block of values (non-divisible) using a write multiple registers command (function code 0x10). Last calibration time can subsequently be read to verify. It utilizes temperature readings of the probe, so they are not needed to be supplied by the user.

Address	Description	R/W	Type	Default
0x0320	Conductivity us/cm Calibration Time (s) [3:0]	W	U32	N/A
0x0321				
0x0322	Conductivity us/cm Calibration Value [3:0]	W	Float	N/A
0x0323				

Request		
Function Code	1 byte	0x10
Register Address	2 bytes	0x0320
Number Registers	2 bytes	0x0004
Byte Count	1 byte	0x08
Register Values	8 bytes	Conductivity us/cm Calibration Time (s) [3:0] Conductivity us/cm Calibration Value [3:0]

Salinity ppt Calibration

Salinity ppt calibration is accomplished by writing an entire block of values (non-divisible) using a write multiple registers command (function code 0x10). Last calibration time can subsequently be read to verify.

Address	Description	R/W	Type	Default
0x0330	Salinity ppt Calibration Time (s) [3:0]	W	U32	N/A
0x0331				
0x0332	Salinity ppt Calibration Value [3:0]	W	Float	N/A
0x0333				

Request		
Function Code	1 byte	0x10
Register Address	2 bytes	0x0330
Number Registers	2 bytes	0x0004
Byte Count	1 byte	0x08
Register Values	8 bytes	Salinity ppt Calibration Time (s) [3:0] Salinity ppt Calibration Value [3:0]

Specific Conductance $\mu\text{s}/\text{cm}$ Calibration

Specific conductance $\mu\text{s}/\text{cm}$ calibration is accomplished by writing an entire block of values (non-divisible) using a write multiple registers command (function code 0x10). Last calibration time can subsequently be read to verify. It utilizes temperature readings of the probe, so they are not needed to be supplied by the user.

Address	Description	R/W	Type	Default
0x0340	Specific Conductivity $\mu\text{s}/\text{cm}$ Calibration Time (s) [3:0]	W	U32	N/A
0x0341				
0x0342	Specific Conductivity $\mu\text{s}/\text{cm}$ Calibration Value [3:0]	W	Float	N/A
0x0343				

Request		
Function Code	1 byte	0x10
Register Address	2 bytes	0x0340
Number Registers	2 bytes	0x0004
Byte Count	1 byte	0x08
Register Values	8 bytes	Specific Conductivity $\mu\text{s}/\text{cm}$ Calibration Time (s) [3:0] Specific Conductivity $\mu\text{s}/\text{cm}$ Calibration Value [3:0]

nLF Calibration

Non-linear function conductivity calibration is accomplished by writing an entire block of values (non-divisible) using a write multiple registers command (function code 0x10). Last calibration time can subsequently be read to verify.

Address	Description	R/W	Type	Default
0x0350	nLF Conductivity $\mu\text{s}/\text{cm}$ Calibration Time (s) [3:0]	W	U32	N/A
0x0351				
0x0352	nLF Conductivity $\mu\text{s}/\text{cm}$ Calibration Value [3:0]	W	Float	N/A
0x0353				

Request		
Function Code	1 byte	0x10
Register Address	2 bytes	0x0350
Number Registers	2 bytes	0x0004
Byte Count	1 byte	0x08
Register Values	8 bytes	nLF Conductivity $\mu\text{s}/\text{cm}$ Calibration Time (s) [3:0] nLF Conductivity $\mu\text{s}/\text{cm}$ Calibration Value [3:0]

5.5

User Values for Derived Parameters

Several values reported by the probe are dependent upon parameters that the probe does not supply. It is, therefore, a requirement of the user to supply these values if the derived parameters are of interest.

Salinity

Salinity values are not required (or available to be set) for ODO/CT probes, as the parameter value is already available. In ODO/T probes, salinity is required for ODO mg/L calculations. The salinity value is set by writing an entire block of values (non-divisible) using a write multiple registers command (function code 0x10). This information can be broadcast to all devices on the network and updated periodically. The default on power-up is 0.0.

Address	Description	R/W	Type	Default
0x0400	User Salinity Value (ppt) [3:0]	RW	Float	0.0
0x0401				

Request		
Function Code	1 byte	0x10
Register Address	2 bytes	0x0400
Number Registers	2 bytes	0x0002
Byte Count	1 byte	0x04
Register Values	4 bytes	User Salinity Value (ppt) [3:0]

Water Pressure

In ODO/CT probes, water pressure is required for salinity calculations. The water pressure value is set by writing an entire block of values (non-divisible) using a write multiple registers command (function code 0x10). This information can be broadcast to all devices on the network and updated periodically. The default on power-up is 0.0.

Address	Description	R/W	Type	Default
0x0402	User Water Pressure Value (psi) [3:0]	RW	Float	0.0
0x0403				

Request		
Function Code	1 byte	0x10
Register Address	2 bytes	0x0402
Number Registers	2 bytes	0x0002
Byte Count	1 byte	0x04
Register Values	4 bytes	User Pressure Value (psi) [3:0]

Barometric Pressure

In all probes, barometric pressure is required for barometer compensated ODO percent saturation calculations. The barometric pressure value is set by writing an entire block of values (non-divisible) using a write multiple registers command (function code 0x10). This information can be broadcast to all devices on the network and updated periodically. The default is 760.0 or the last calibration value given, if available.

Address	Description	R/W	Type	Default
0x0404	User Barometric Pressure Value (mmHg) [3:0]	RW	Float	760.0 or last value from calibration
0x0405				

Request		
Function Code	1 byte	0x10
Register Address	2 bytes	0x0404
Number Registers	2 bytes	0x0002
Byte Count	1 byte	0x04
Register Values	4 bytes	User Barometric Pressure Value (mmHg) [3:0]

5.6

Conductivity Settings

Derived parameters from the conductivity sensor can be adapted by the user. This affects specific conductance and total dissolved solids (TDS) values.

TDS Coefficient

In ODO/CT probes, the coefficient used to calculate TDS can be modified by the user. The value is set by writing an entire block of values (non-divisible) using a write multiple registers command (function code 0x10). This information can be broadcast to all devices on the network. The default value is 0.65 and is saved over power cycles. Valid values range from 0.3 to 1.0.

Address	Description	R/W	Type	Default
0x0500	TDS Coefficient [3:0]	RW	Float	0.65
0x0501				

Request		
Function Code	1 byte	0x10
Register Address	2 bytes	0x0500
Number Registers	2 bytes	0x0002
Byte Count	1 byte	0x04
Register Values	4 bytes	TDS Coefficient [3:0]

Specific Conductance Temperature Reference

In ODO/CT probes, the standard temperature reference used to calculate specific conductance can be modified by the user. The value is set by writing an entire block of values (non-divisible) using a write multiple registers command (function code 0x10). This information can be broadcast to all devices on the network. The default value is 25C and is saved over power cycles. Valid values range from 15C to 25C.

Address	Description	R/W	Type	Default
0x0502	Specific Conductance Temperature Reference (C) [3:0]	RW	Float	25
0x0503				

Request		
Function Code	1 byte	0x10
Register Address	2 bytes	0x0502
Number Registers	2 bytes	0x0002
Byte Count	1 byte	0x04
Register Values	4 bytes	Specific Conductance Temperature Reference (C) [3:0]

Specific Conductance Temperature Coefficient

In ODO/CT probes, the standard temperature reference coefficient used to calculate specific conductance can be modified by the user. The value is set by writing an entire block of values (non-divisible) using a write multiple registers command (function code 0x10). This information can be broadcast to all devices on the network. The default value is 0.0191 and is saved over power cycles. Valid values range from 0 to 0.04.

Address	Description	R/W	Type	Default
0x0504	Specific Conductance Temperature Coefficient [3:0]	RW	Float	0.0191
0x0505				

Request		
Function Code	1 byte	0x10
Register Address	2 bytes	0x0504
Number Registers	2 bytes	0x0002
Byte Count	1 byte	0x04
Register Values	4 bytes	Specific Conductance Temperature Coefficient [3:0]

5.7

Appendix A: Register Mapping Tables

Input Registers

Address	Description	R/W	Type
0x0000	ODO Saturation (%) [3:0]	R	Float
0x0001			
0x0002	ODO (mg/L) [3:0]	R	Float
0x0003			
0x0004	ODO Local Barometer Compensated (%) [3:0]	R	Float
0x0005			
0x0006	Temperature (C) [3:0]	R	Float
0x0007			
0x0008	Reference Temperature (C) [3:0]	R	Float
0x0009			
0x000A	Time Since Boot (ms) [3:0]	R	U32
0x000B			
0x000C	Conductivity (us/cm) [3:0]	R	Float
0x000D			
0x000E	Specific Conductivity (us/cm) [3:0]	R	Float
0x000F			
0x0010	Salinity (ppt) [3:0]	R	Float
0x0011			
0x0012	Conductivity nLF (us/cm) [3:0]	R	Float
0x0013			
0x0014	Total Dissolved Solids (mg/L) [3:0]	R	Float
0x0015			
0x0016	Reserved [3:0]	R	Float
0x0017			
0x0018	Reserved [3:0]	R	U32
0x0019			
0x001A	Reserved [3:0]	R	Float
0x001B			
0x001C	Reserved [3:0]	R	Float
0x001D			
0x001E	Reserved [3:0]	R	Float
0x001F			

Read/Write Multiple Registers

Address	Description	R/W	Type	Default
0x0100	ODO Cap Coefficient K1 [3:0]	RW	U32	N/A
0x0101				
0x0102	ODO Cap Coefficient K2 [3:0]	RW	U32	N/A
0x0103				
0x0104	ODO Cap Coefficient K3 [3:0]	RW	U32	N/A
0x0105				
0x0106	ODO Cap Coefficient K4 [3:0]	RW	U32	N/A
0x0107				
0x0108	ODO Cap Coefficient K5 [3:0]	RW	U32	N/A
0x0109				
0x010A	ODO Cap Coefficient K6 [3:0]	RW	U32	N/A
0x010B				
0x010C	ODO Cap Coefficient K7 [3:0]	RW	U32	N/A
0x010D				
0x010E	ODO Cap Coefficient KC [3:0]	RW	U16	N/A
0x010F	ODO Cap Replacement Time (s) [3:0]	RW	U32	N/A
0x0110				
0x0120	ODO Cap Serial Number [0:8] + pad	R	ASCII	N/A
0x0121				
0x0122				
0x0123				
0x0124				
0x0210	ODO Last Calibration Time (s) [3:0]	R	U32	N/A
0x0211				
0x0212	ODO Calibration QC Score	R	U16	N/A
0x0220	ODO Zero Calibration Time (s) [3:0]	W	U32	N/A
0x0221				
0x0230	ODO % Calibration Time (s) [3:0]	W	U32	N/A
0x0231				
0x0232	ODO % Calibration Barometer (mmHg) [3:0]	W	Float	N/A
0x0233				

0x0240	ODO mg/L Calibration Time (s) [3:0]	W	U32	N/A
0x0241				
0x0242	ODO mg/L Calibration Value [3:0]	W	Float	N/A
0x0243				
0x0244	ODO mg/L Calibration Salinity (ppt) [3:0]	W	Float	N/A
0x0245				
0x0310	Conductivity Last Calibration Time (s) [3:0]	R	U32	N/A
0x0311				
0x0312	Conductivity Calibration QC Score	R	U16	N/A
0x0320	Conductivity us/cm Calibration Time (s) [3:0]	W	U32	N/A
0x0321				
0x0322	Conductivity us/cm Calibration Value [3:0]	W	Float	N/A
0x0323				
0x0330	Salinity ppt Calibration Time (s) [3:0]	W	U32	N/A
0x0331				
0x0332	Salinity ppt Calibration Value [3:0]	W	Float	N/A
0x0333				
0x0340	Specific Conductivity us/cm Calibration Time (s) [3:0]	W	U32	N/A
0x0341				
0x0342	Specific Conductivity us/cm Calibration Value [3:0]	W	Float	N/A
0x0343				
0x0350	nLF Conductivity us/cm Calibration Time (s) [3:0]	W	U32	N/A
0x0351				
0x0352	nLF Conductivity us/cm Calibration Value [3:0]	W	Float	N/A
0x0353				
0x0400	User Salinity Value (ppt) [3:0]	RW	Float	0.0
0x0401				
0x0402	User Water Pressure Value (psi) [3:0]	RW	Float	0.0
0x0403				
0x0404	User Barometric Pressure Value (mmHg) [3:0]	RW	Float	760.0 or last value from calibration
0x0405				
0x0500	TDS Coefficient [3:0]	RW	Float	N/A
0x0501				

0x0502	Specific Conductance Temperature Reference (C) [3:0]	RW	Float	N/A
0x0503				
0x0504	Specific Conductance Temperature Coefficient [3:0]	RW	Float	N/A
0x0505				
0x1000	Product [1:0]	R	U16	0x0003
0x1001	Model [1:0]	R	U16	0x0001
0x1002	Submodel [1:0]	R	U16	0x0001 (CT) 0x0002 (T)
0x1003	Firmware Major Revision [1:0]	R	U16	N/A
0x1004	Firmware Minor Revision [1:0]	R	U16	N/A
0x1005	Firmware Subminor Revision [1:0]	R	U16	N/A
0x1006	Hardware Major Revision [1:0]	R	U16	N/A
0x1007	Hardware Minor Revision [1:0]	R	U16	N/A
0x1008	Manufacturing Serial Number [0:8] + pad	R	ASCII	N/A
0x1009				
0x100A				
0x100B				
0x100C				
0x100D	Printed Circuit Board Serial Number [0:7]	R	ASCII	N/A
0x100E				
0x100F				
0x1010				

Read/Write Single Registers

Address	Description	R/W	Type	Default
0x0000	Slave Address	RW	U16	0x0001
0x0001	Serial Configuration [1] : Parity 0x00 - None 0x01 - Odd 0x02 - Even [0] : Baud 0x00 - 9600 0x01 - 19200 0x02 - 38400 0x03 - 57600 0x04 - 115200	RW	U16	0x0200
0x0200	Factory Reset ODO Calibration 0x0001 - Reset	W	U16	N/A
0x0300	Factory Reset Conductivity Calibration 0x0001 - Reset	W	U16	N/A

6. Accessories

6.1 Ordering

Telephone: 800 897 4151 (USA)

+1 937 767 7241 (Globally) Monday through Friday

8:00 AM to 5:00 ET

Fax: +1 937 767 9353 (orders)

Email: info@ysi.com

Mail: YSI Incorporated 1725 Brannum Lane

Yellow Springs, OH 45387 USA

Web: Visit YSI.com to order replacement parts, accessories, and calibration solutions.

When placing an order please have the following available:

1. YSI account number (if available)
2. Name and phone number
3. Purchase Order or Credit Card number
4. Model Number or brief description
5. Billing and shipping addresses
6. Quantity

Probe Assemblies

NOTE: The ODO and OBOD sensor caps come pre-installed on the following probe assemblies, with calibration coefficients of the sensor cap pre-loaded into the probe at the factory.

YSI Item #	Description
	Optical Dissolved Oxygen and Temperature Probes
627350-1	ODO RTU Probe Assembly, 1m
627350-4	ODO RTU Probe Assembly, 4m
627350-10	ODO RTU Probe Assembly, 10m
627350-20	ODO RTU Probe Assembly, 20m
627350-30	ODO RTU Probe Assembly, 30m
627350-50	ODO RTU Probe Assembly, 50m
627350-100	ODO RTU Probe Assembly, 100m
	Optical Dissolved Oxygen, Conductivity, and Temperature Probes
627370-1	ODO RTU Probe Assembly with Conductivity, 1m
627370-4	ODO RTU Probe Assembly with Conductivity, 4m
627370-10	ODO RTU Probe Assembly with Conductivity, 10m
627370-20	ODO RTU Probe Assembly with Conductivity, 20m
627370-30	ODO RTU Probe Assembly with Conductivity, 30m
627370-50	ODO RTU Probe Assembly with Conductivity, 50m
627370-100	ODO RTU Probe Assembly with Conductivity, 100m

Replacement ODO Sensor Caps, Standards, and Accessories

YSI Item #	Description
	Replacement ODO Sensor Caps
627180	Replacement ODO Extended Warranty Sensor Cap (only compatible with ODO/T and ODO/CT probe assemblies)
	Calibration Standards
065270	Conductivity standard, 1000 $\mu\text{mhos/cm}$ (quart, glass); ideal for fresh water
065272	Conductivity standard, 10000 $\mu\text{mhos/cm}$ (quart, glass); ideal for brackish water
065274	Conductivity standard, 100000 $\mu\text{mhos/cm}$ (quart, glass); ideal for supersaturated sea water
060907	Conductivity standard, 1000 $\mu\text{mhos/cm}$ (box of 8 individual pints, plastic); ideal for fresh water
060906	Conductivity standard, 1413 $\mu\text{mhos/cm}$, $\pm 1\%$, 0.01 M KCl (box of 8 individual pints, plastic)
060911	Conductivity standard, 10000 $\mu\text{mhos/cm}$ (box of 8 individual pints, plastic); ideal for brackish water
060660	Conductivity standard, 50000 $\mu\text{mhos/cm}$ (box of 8 individual pints, plastic); ideal for sea water
	Other Accessories
603076	Flow cell for ODO/CT cables (requires single port adapter; 603078)
603078	Adapter required for ODO/CT flow cell (603076)
603056	Flow cell mounting spike
627195	Calibration cup for ODO/CT cable assembly (included with all ODO/CT cables)
605978	Weight, 4.9 oz
603062	Cable management kit (included with ODO/CT cables 4, 10, 20, and 30-meters long; and ODO/T cables 4, 10, 20, and 30-meters long)

7. Safety and Support

7.1 Service Information

YSI has authorized service centers throughout the United States and Internationally. For the nearest service center information, please visit ysi.com and click 'Support' or contact YSI Technical Support directly at 800-897-4151 (+1 937-767-7241).

When returning a product for service, include the Product Return form with cleaning certification. The form must be completely filled out for a YSI Service Center to accept the instrument for service. The form may be downloaded from YSI.com.

7.2 Technical Support

Telephone: 800 897 4151 (USA)

+1 937 767 7241 (Globally) Monday through Friday, 8:00 AM to 5:00 ET

Fax: +1 937 767 9353 (orders)

Email: info@ysi.com

Mail: YSI Incorporated 1725 Brannum Lane Yellow Springs, OH 45387 USA

Internet: YSI.com

7.3

Declaration of Conformity

The undersigned hereby declares on behalf of the named manufacturer under our sole responsibility that the listed product conforms to the requirements for the listed European Council Directive(s) and carries the CE mark accordingly.

<i>Manufacturer:</i>	YSI Incorporated 1725 Brannum Lane Yellow Springs, OH 45387 USA
<i>Product Name:</i>	ODO RTU
<i>Conforms to the following:</i>	
<i>Directives:</i>	EMC 2004/108/EC RoHS 2011/65/EU WEEE 2012/19/EU
<i>Harmonized Standards:</i>	EN61326-1:2013 (IEC 61326-1:2012) IEC 61000-3-2:2005 +A1:2008+A2:2009 IEC 61000-3-3:2008
<i>Supplementary Information:</i>	All performance met the operation criteria as follows: 1. ESD, IEC 61000-4-2:2008 2. Radiated Immunity, IEC 61000-4-3:2006 +A1:2007+A2:2010 3. Electrical Fast Transient (EFT), IEC 61000-4-4:2004 +A1:2010 4. Immunity to Surge, IEC 61000-4-5:2005 5. Radio Frequency, Continuous Conducted Immunity, IEC61000-4-6:2008 6. IEC 61000-4-8:2009 7. IEC 61000-4-11:2004
<i>Authorized EU Representative</i>	Xylem Analytics UK Ltd Unit 2 Focal Point, Lacerta Court, Works Road Letchworth, Hertfordshire, SG6 1FJ UK

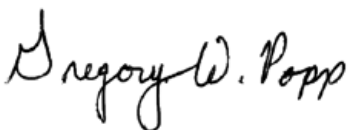

Signed: Gregory Popp
Title: Quality Manager

Date: January 28, 2021

The undersigned hereby declares on behalf of the named manufacturer under our sole responsibility that the listed product conforms to the requirements for electrical equipment under US FCC Part 15 and ICES-003 for unintentional radiators.

<i>Manufacturer:</i>	YSI Incorporated 1725 Brannum Lane Yellow Springs, OH 45387 USA
<i>Product Name:</i>	Professional Digital Sampling System Instrument
<i>Model Numbers</i>	
<i>Instrument/Accessory:</i>	ODO RTU (627350), ODO RTU with Conductivity (627370)
<i>Probe/Cable Assemblies:</i>	627350-1, 627350-4, 627350-10, 627350-20, 627350-30, 627350-50, 627350-100 627370-1, 627370-4, 627370-10, 627370-20, 627370-30, 627370-50, 627370-100
<i>Conforms to the following:</i>	
<i>Standards:</i>	<ul style="list-style-type: none"> • FCC 47 CFR Part 15-2008, Subpart B, Class B, Radio Frequency Devices • ICES-003:2004, Digital Apparatus
<i>Supplementary Information:</i>	Tested using ANSI C63.4-2003 (excluding sections 4.1, 5.2, 5.7, 9, and 14)



Signed: Gregory Popp
Title: Quality Manager

Date: January 28, 2021

7.4

Warranty

The YSI ODO RTU (ODO/CT and ODO/T) are warranted for two (2) years from date of purchase by the end user against defects in material and workmanship. The ODO Extended Warranty Sensor Cap (627180) for the ODO/T and ODO/CT cable assemblies is warranted for two (2) years from date of purchase by the end user against defects in material and workmanship. Optical ODO sensor caps (all but the 627180 cap previously mentioned) are warranted for one (1) year from date of purchase by the end user against defects in material and workmanship. Within the warranty period, YSI will repair or replace, at its sole discretion, free of charge, any product that YSI determines to be covered by this warranty.

To exercise this warranty, call your local YSI representative, or contact YSI Customer Service in Yellow Springs, Ohio at +1 937 767-7241, 800-897-4151 or visit www.YSI.com (Support tab) for a Product Return Form. Send the product and proof of purchase, transportation prepaid, to the Authorized Service Center selected by YSI. Repair or replacement will be made and the product returned, transportation prepaid. Repaired or replaced products are warranted for the balance of the original warranty period, or at least 90 days from date of repair or replacement.

LIMITATION OF WARRANTY

This Warranty does not apply to any YSI product damage or failure caused by:

1. Failure to install, operate or use the product in accordance with YSI's written instructions;
2. Abuse or misuse of the product;
3. Failure to maintain the product in accordance with YSI's written instructions or standard industry procedure;
4. Any improper repairs to the product;
5. Use by you of defective or improper components or parts in servicing or repairing the product;
6. Modification of the product in any way not expressly authorized by YSI.

THIS WARRANTY IS IN LIEU OF ALL OTHER WARRANTIES, EXPRESSED OR IMPLIED, INCLUDING ANY WARRANTY OF MERCHANTABILITY OR FITNESS FOR A PARTICULAR PURPOSE. YSI's LIABILITY UNDER THIS WARRANTY IS LIMITED TO REPAIR OR REPLACEMENT OF THE PRODUCT, AND THIS SHALL BE YOUR SOLE AND EXCLUSIVE REMEDY FOR ANY DEFECTIVE PRODUCT COVERED BY THIS WARRANTY. IN NO EVENT SHALL YSI BE LIABLE FOR ANY SPECIAL, INDIRECT, INCIDENTAL OR CONSEQUENTIAL DAMAGES RESULTING FROM ANY DEFECTIVE PRODUCT COVERED BY THIS WARRANTY.

8. Appendices

8.1

Appendix B DO% Calibration Values

Calibration Value D.O. %	Pressure			
	in Hg	mmHg	kPa	mbar
101%	30.22	767.6	102.34	1023.38
100%	29.92	760.0	101.33	1013.25
99%	29.62	752.4	100.31	1003.12
98%	29.32	744.8	99.30	992.99
97%	29.02	737.2	98.29	982.85
96%	28.72	729.6	97.27	972.72
95%	28.43	722.0	96.26	962.59
94%	28.13	714.4	95.25	952.46
93%	27.83	706.8	94.23	942.32
92%	27.53	699.2	93.22	932.19
91%	27.23	691.6	92.21	922.06
90%	26.93	684.0	91.19	911.93
89%	26.63	676.4	90.18	901.79
88%	26.33	668.8	89.17	891.66
87%	26.03	661.2	88.15	881.53
86%	25.73	653.6	87.14	871.40
85%	25.43	646.0	86.13	861.26
84%	25.13	638.4	85.11	851.13
83%	24.83	630.8	84.10	841.00
82%	24.54	623.2	83.09	830.87
81%	24.24	615.6	82.07	820.73
80%	23.94	608.0	81.06	810.60
79%	23.64	600.4	80.05	800.47
78%	23.34	592.8	79.03	790.34
77%	23.04	585.2	78.02	780.20
76%	22.74	577.6	77.01	770.07
75%	22.44	570.0	75.99	759.94
74%	22.14	562.4	74.98	749.81
73%	21.84	554.8	73.97	739.67
72%	21.54	547.2	72.95	729.54

8.2

Appendix C Oxygen Solubility Table

Solubility of oxygen in mg/L in water exposed to water-saturated air at 760 mm Hg pressure.

Salinity = Measure of quantity of dissolved salts in water.

Chlorinity = Measure of chloride content, by mass, of water.

$$S(0/00) = 1.80655 \times \text{Chlorinity (0/00)}$$

Temp °C	Chlorinity : 0 Salinity: 0	5.0 ppt 9.0 ppt	10.0 ppt 18.1 ppt	15.0 ppt 27.1 ppt	20.0 ppt 36.1 ppt	25.0 ppt 45.2 ppt
0.0	14.62	13.73	12.89	12.10	11.36	10.66
1.0	14.22	13.36	12.55	11.78	11.07	10.39
2.0	13.83	13.00	12.22	11.48	10.79	10.14
3.0	13.46	12.66	11.91	11.20	10.53	9.90
4.0	13.11	12.34	11.61	10.92	10.27	9.66
5.0	12.77	12.02	11.32	10.66	10.03	9.44
6.0	12.45	11.73	11.05	10.40	9.80	9.23
7.0	12.14	11.44	10.78	10.16	9.58	9.02
8.0	11.84	11.17	10.53	9.93	9.36	8.83
9.0	11.56	10.91	10.29	9.71	9.16	8.64
10.0	11.29	10.66	10.06	9.49	8.96	8.45
11.0	11.03	10.42	9.84	9.29	8.77	8.28
12.0	10.78	10.18	9.62	9.09	8.59	8.11
13.0	10.54	9.96	9.42	8.90	8.41	7.95
14.0	10.31	9.75	9.22	8.72	8.24	7.79
15.0	10.08	9.54	9.03	8.54	8.08	7.64
16.0	9.87	9.34	8.84	8.37	7.92	7.50
17.0	9.67	9.15	8.67	8.21	7.77	7.36
18.0	9.47	8.97	8.50	8.05	7.62	7.22
19.0	9.28	8.79	8.33	7.90	7.48	7.09
20.0	9.09	8.62	8.17	7.75	7.35	6.96
21.0	8.92	8.46	8.02	7.61	7.21	6.84
22.0	8.74	8.30	7.87	7.47	7.09	6.72
23.0	8.58	8.14	7.73	7.34	6.96	6.61
24.0	8.42	7.99	7.59	7.21	6.84	6.50
25.0	8.26	7.85	7.46	7.08	6.72	6.39
26.0	8.11	7.71	7.33	6.96	6.62	6.28
27.0	7.97	7.58	7.20	6.85	6.51	6.18
28.0	7.83	7.44	7.08	6.73	6.40	6.09
29.0	7.69	7.32	6.93	6.62	6.30	5.99
30.0	7.56	7.19	6.85	6.51	6.20	5.90
31.0	7.43	7.07	6.73	6.41	6.10	5.81
32.0	7.31	6.96	6.62	6.31	6.01	5.72

Temp °C	Chlorinity : 0 Salinity: 0	5.0 ppt 9.0 ppt	10.0 ppt 18.1 ppt	15.0 ppt 27.1 ppt	20.0 ppt 36.1 ppt	25.0 ppt 45.2 ppt
33.0	7.18	6.84	6.52	6.21	5.91	5.63
34.0	7.07	6.73	6.42	6.11	5.82	5.55
35.0	6.95	6.62	6.31	6.02	5.73	5.46
36.0	6.84	6.52	6.22	5.93	5.65	5.38
37.0	6.73	6.42	6.12	5.84	5.56	5.31
38.0	6.62	6.32	6.03	5.75	5.48	5.23
39.0	6.52	6.22	5.98	5.66	5.40	5.15
40.0	6.41	6.12	5.84	5.58	5.32	5.08
41.0	6.31	6.03	5.75	5.49	5.24	5.01
42.0	6.21	5.93	5.67	5.41	5.17	4.93
43.0	6.12	5.84	5.58	5.33	5.09	4.86
44.0	6.02	5.75	5.50	5.25	5.02	4.79
45.0	5.93	5.67	5.41	5.17	4.94	4.72

Xylem |'zīləm|

- 1) The tissue in plants that brings water upward from the roots;
- 2) a leading global water technology company.



We're a global team unified in a common purpose: creating advanced technology solutions to the world's water challenges. Developing new technologies that will improve the way water is used, conserved, and re-used in the future is central to our work. Our products and services move, treat, analyze, monitor and return water to the environment, in public utility, industrial, residential and commercial building services settings. Xylem also provides a leading portfolio of smart metering, network technologies and advanced analytics solutions for water, electric and gas utilities. In more than 150 countries, we have strong, long-standing relationships with customers who know us for our powerful combination of leading product brands and applications expertise with a strong focus on developing comprehensive, sustainable solutions.

For more information on how Xylem can help you, go to www.xylem.com

Who's
Minding
the Planet?®

xylem
Let's Solve Water

YSI, a Xylem brand
1725 Brannum Lane
Yellow Springs, OH 45387

 +1.937.767.7241
 info@ysi.com
 ysi.com



YSI.com/ODORTU